



 A BTR Metering Systems Company

**Parts List
2" and 3" T-10 HP
Turbo-Meters**

**Parts List
2" & 3" T-10 HP
Turbo-Meters**

**2" T-10 HP Turbo-Meter
General Assembly Cross Section**

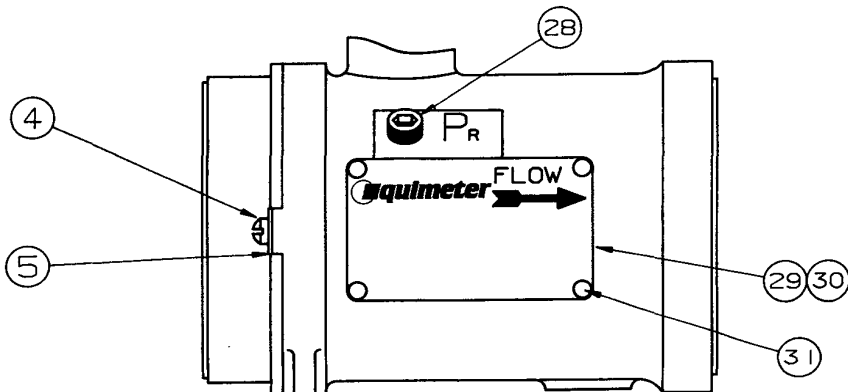
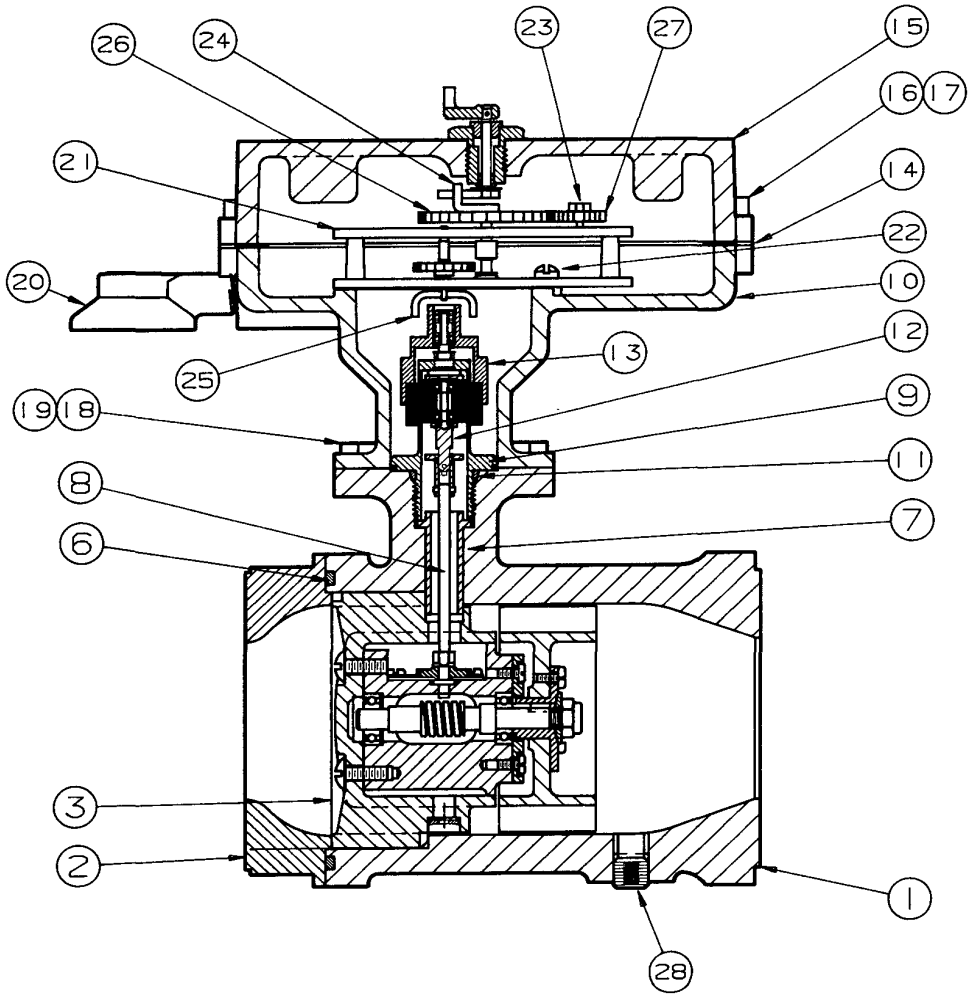

2" T-10 HP Turbo-Meter

ILLUSTRATION NUMBER	QUANTITY REQUIRED	PART DESCRIPTION	PART NUMBER
1	1	Body Assembly, ANSI #150, 275# W.P.	006-15-611-00
1	1	Body Assembly, ANSI #600, 1440# W.P.	006-15-611-80
2	1	Body Flange	006-15-101-00
3	1	Metering Rotor Module	006-19-550-00
4	2	#10-24 UNC x 5/8 lg. Fil. Hd. Machine Screw	903389
5	2	#10 Steel Washer	907687
6	1	O-Ring, #2-237 Buna-N	950504
7	1	Bushing	006-15-082-00
8	1	Coupling Shaft Assembly	006-15-345-00
9	1	Magnet Well & Post Assembly	006-19-244-00
10	1	Instrument Mounting Housing	006-19-107-01
11	1	O-Ring, #3-908 Buna-N	950466
12	1	Driver Magnet Holder and Bearing Assembly	006-31-334-00
13	1	Follower Magnet And Bearing Assembly	006-24-313-20
14	1	Index Plate Gasket	006-24-160-03
15	1	Index Plate Assembly	006-24-504-21
16	3	5/16-18 x 3/4 lg. Hex Hd. Cap Screw	910028
17	1	Seal Screw	002-65-057-02
18	3	1/4-20 x 1/2 lg. S.S. Hex Hd. Machine Screw	950463
19	1	Seal Screw	006-19-057-00
20	1	Vent Cap	006-24-505-01
21	1	Intermediate Gear Assembly 100 CF	006-24-212-40
21	1	Intermediate Gear Assembly 1.0 m ³	006-24-212-41
22	3	#8-32 x 3/8 lg. Fil. Hd. Machine Screw	903371
23	1	#4-40 S.S. Hex Nut	907639
24	1	Intermediate Gear Output Dog (Top)	002-66-071-03
25	1	Intermediate Gear Output Dog (Bottom)	006-24-061-20
26	1	Large Change Gear <i>NOTE: "xx" refers to gear blank diameter; size "yy" refers to number of teeth. Digits must be substituted for "xx" and "yy" when ordering.</i>	006-24-3xx-yy
27	1	Small Change Gear <i>(Refer to NOTE for #26 above)</i>	006-24-3xx-yy
28	2	Pipe Plug	902448
29	1	Nameplate 275# W.P.	006-15-074-00555
30	1	Nameplate 1440# W.P.	006-15-074-80555
31	4	#4-3/16 lg. Brass Round Hd. Drive Screw	903004
32*	1	Cover Plate on Instrument Mounting Housing	006-20-031-00
33*	2	#4-40 x 1/4 lg. Round Hd. Machine Screw <i>(For mounting cover plate)</i>	903025
34*	1	Cover Plate Gasket	950661

* Not Shown

**3" T-10 HP Turbo-Meter
General Assembly Cross Section**

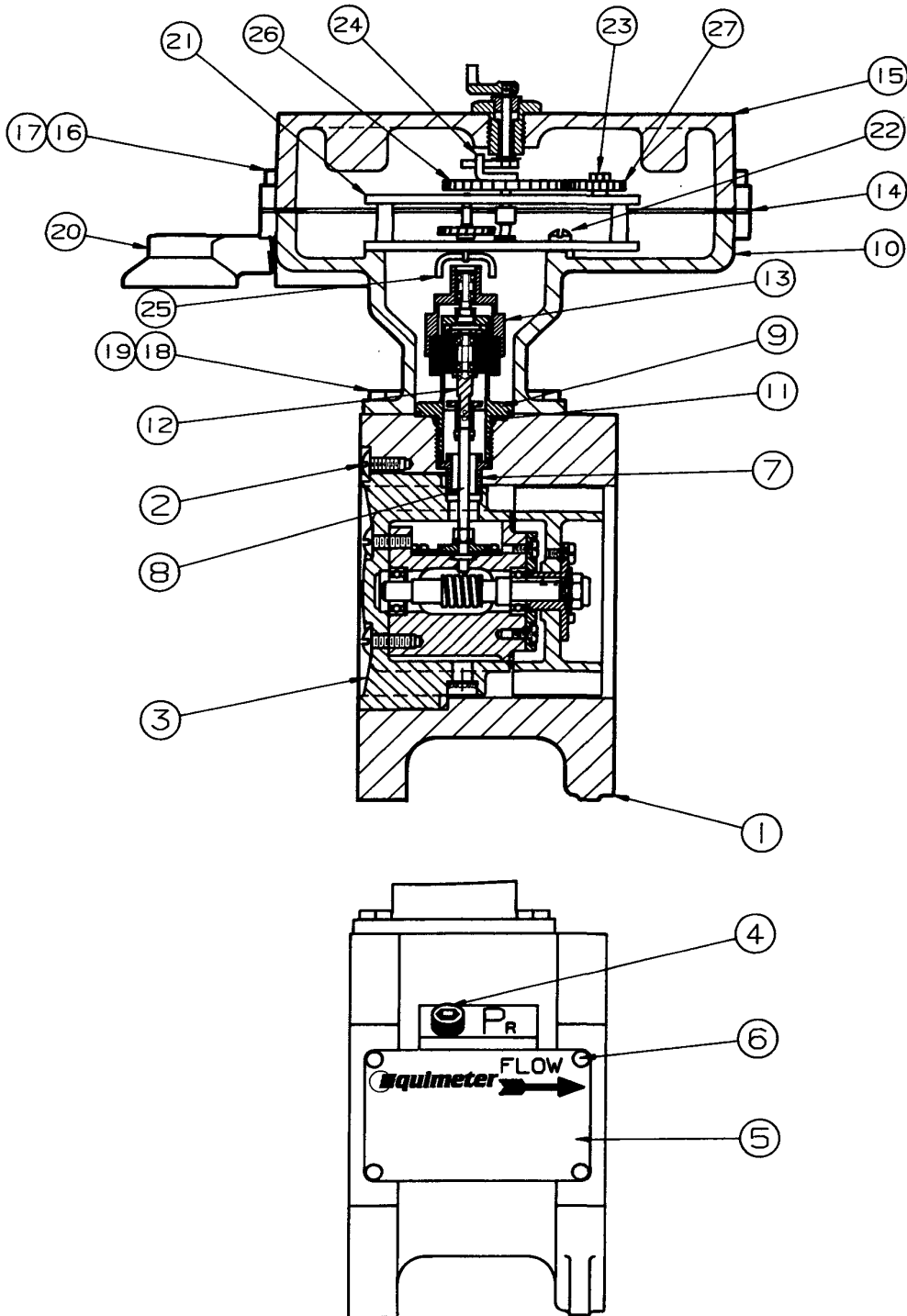

3" T-10 HP Turbo-Meter

ILLUSTRATION NUMBER	QUANTITY REQUIRED	PART DESCRIPTION	PART NUMBER
1	1	Body Assembly, ANSI #600, 1440# W.P.	006-19-611-80
2	3	#8-32 3/8 lg. Truss Hd. Machine Screw w/Nylok	950529
3	1	Metering Rotor Module	006-19-550-00
4	1	Pipe Plug	902448
5	1	Nameplate 1440# W.P.	006-19-074-00555
6	4	#4 x 13/16 lg. Brass Round Hd. Drive Screw	903004
7	1	Bushing	006-19-082-00
8	1	Coupling Shaft Assembly	006-19-345-00
9	1	Magnet Well & Post Assembly	006-19-244-00
10	1	Instrument Mounting Housing	006-19-107-01
11	1	O-Ring, #3-908 Buna-N	950466
12	1	Driver Magnet Holder and Bearing Assembly	006-31-334-00
13	1	Follower Magnet and Bearing Assembly	006-24-313-20
14	1	Index Plate Gasket	006-24-160-03
15	1	Index Plate Assembly	006-24-504-21
16	3	5/16-18 x 3/4 lg. Hex Hd. Cap Screw	910028
17	1	Seal Screw	002-65-057-02
18	3	1/4-20 x 1/2 lg. S.S. Hex Hd. Machine Screw	950463
19	1	Seal Screw	006-19-057-00
20	1	Vent Cap	006-24-505-01
21	1	Intermediate Gear Assembly 100 CF	006-24-212-40
21	1	Intermediate Gear Assembly 1.0 m ³	006-24-212-41
22	3	#8-32 x 3/8 lg. Fil. Hd. Machine Screw	903371
23	1	#4-40 S.S. Hex Nut	907639
24	1	Intermediate Gear Output Dog (Top)	002-66-071-03
25	1	Intermediate Gear Output Dog (Bottom)	006-24-061-20
26	1	Large Change Gear <i>NOTE: "xx" refers to gear blank diameter size; "yy" refers to number of teeth. Digits must be substituted for "xx" and "yy" when ordering.</i>	006-24-3xx-yy
27	1	Small Change Gear <i>(Refer to NOTE for #26 above)</i>	006-24-3xx-yy
28*	1	Cover Plate on Instrument Mounting Housing	006-20-031-00
29*	2	#4-40 x 1/4 lg. Round Hd. Machine Screw <i>(For mounting cover plate)</i>	903025
30*	1	Cover Plate Gasket	950661

* Not Shown

**2" & 3" T-10 Metering Rotor Module
(Complete Assembly 006-19-550-00)**

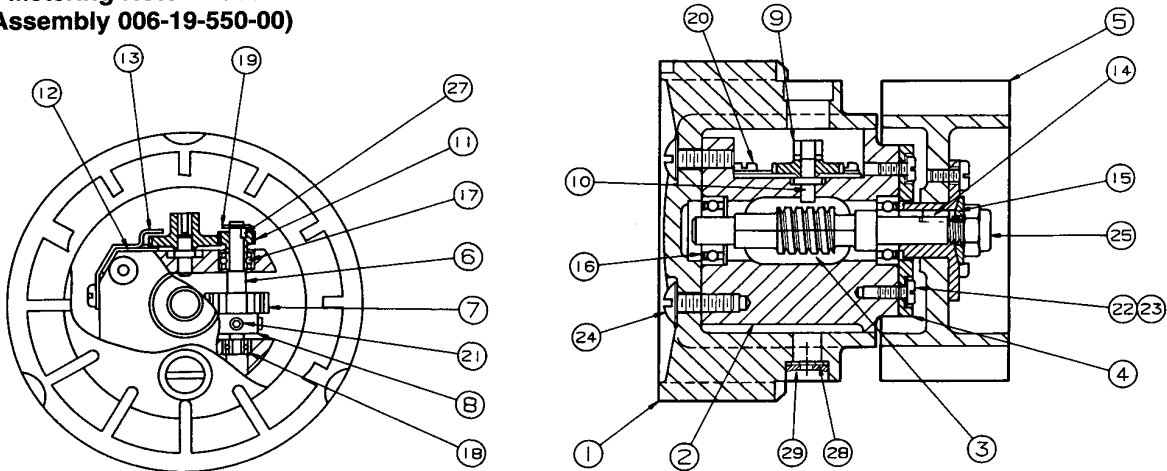

2" & 3" T-10 Metering Rotor Module (Complete Assembly 006-19-550-00)

ILLUSTRATION NUMBER	QUANTITY REQUIRED	PART DESCRIPTION	PART NUMBER
1	1	Nosecone & Bearing Bracket Carrier Assembly	006-19-519-00
2	1	Bearing Bracket & Pin Assembly	006-19-221-00
3	1	Rotor Shaft	006-19-024-00
4	1	Bearing Retainer Plate	006-19-117-00
5	1	Rotor Assembly	006-19-350-00
6	1	Wormwheel Shaft & 19T Gear	006-19-046-00
7	1	Wormwheel (28T)	006-19-035-00
8	1	Wormwheel Hub	006-19-070-00
9	1	38T Upshaft Gear	006-19-438-38
10	1	38T Gear Post	006-19-081-00
11	1	19T Gear	006-19-419-00
12	1	Oil Reservoir Gasket	006-19-160-00
13	1	Oil Reservoir Cover	006-19-053-00
14	1	Key .09 SQ.	006-19-069-00
15	1	Spherical Washer	006-19-077-00
16	2	Bearing	950306
17	1	Bearing	908660
18	1	Bearing	905462
19	1	Retaining Ring	950510
20	4	#4-40 x 1/8 lg. S.S. Pan Hd. Machine Screw	1191260
21	2	#4-40 x 1/8 lg. S.S. Hex Hd. Set Screw	950305
22	2	#4-40 x 1/4 lg. S.S. Pan Hd. Machine Screw	950380
23	2	#4 S.S. External Lock Washer	950078
24	2	#8-32 x 1/2 lg. Truss Hd. Machine Screw w/Nylok	950676
25	1	1/4-20 Locknut	908661
26*	14	Oil Wick - .09 x .09 square	1191430
27	1	Locking Pin - .062 diameter S.S.	006-19-020-00
28	2	Filter Screen	006-22-083-01
29	2	Retaining Ring	904419

* Not Shown

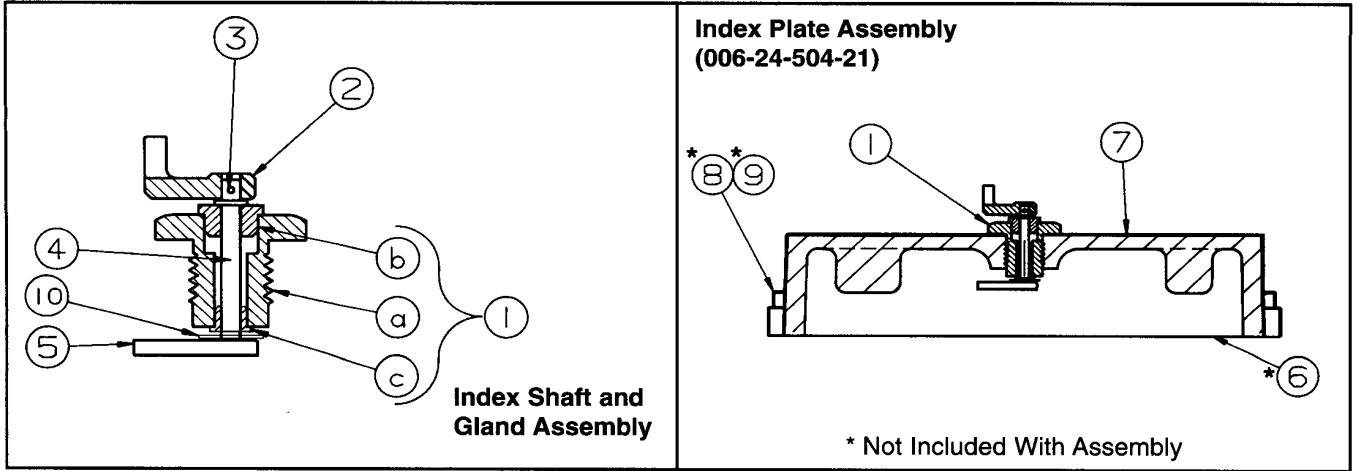

ILLUSTRATION NUMBER	QUANTITY REQUIRED	PART DESCRIPTION	PART NUMBER
1	1	Index Shaft and Gland Assembly (Includes Illustration Numbers 1 a-c)	006-24-323-00
1 a	1	Gland	006-24-023-00
1 b	1	Bushing (Top)	006-24-052-01
1 c	1	Bushing (Bottom)	001-60-052-62
2	1	Top Index Shaft Dog	006-24-061-04
3	1	Shear Pin, Top Index Shaft Dog	006-24-056-00
4	1	Index Shaft	006-24-054-02
5	1	Bottom Index Shaft Dog	006-24-071-00
6	1	Gasket, Index Plate	006-24-160-03
7	1	Index Plate	006-24-004-21
8	3	5/16-18 x 3/4" lg. Hex Hd. Cap Screw (Index Plate to Housing)	910028
9	1	5/16-18 x 3/4" lg. Hex Hd. Seal Screw (Index Plate to Housing)	002-65-057-02
10	1	Retaining Ring	950578

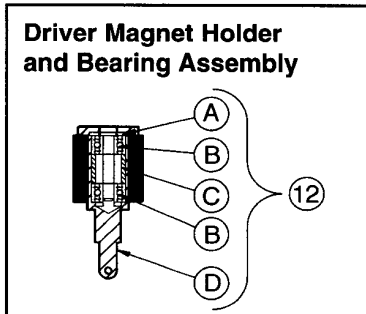

ILLUSTRATION NUMBER	QUANTITY REQUIRED	PART DESCRIPTION	PART NUMBER
12	1	Driver Magnet Holder and Bearing Assembly (Includes Illustration Numbers 12 a-d)	006-31-334-00
12 a	1	Retaining Ring, E-Clip	904691
12 b	2	Bearing	905462
12 c	1	Spacer	006-22-106-03
12 d	1	Driver Magnet and Pin Assembly	006-31-234-02

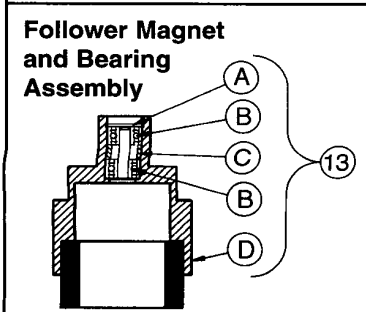
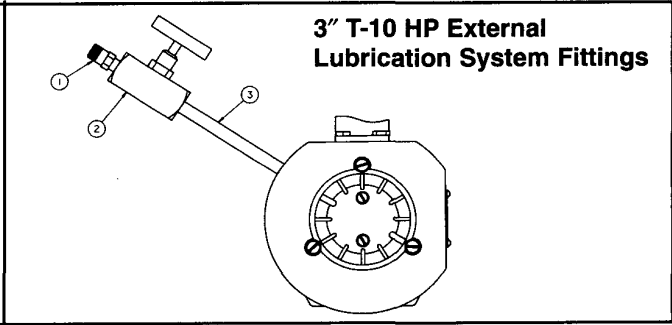
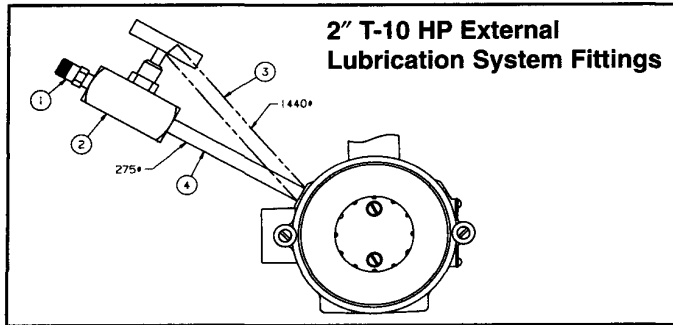

ILLUSTRATION NUMBER	QUANTITY REQUIRED	PART DESCRIPTION	PART NUMBER
13	1	Follower Magnet and Bearing Assembly (Includes Illustration Numbers 13 a-d)	006-24-313-20
13 a	1	Retaining Ring, E-Clip	904691
13 b	2	Bearing	905462
13 c	1	Spacer	006-22-106-03
13 d	1	Follower Magnet and Holder Assembly	006-24-213-20



2" T-10 HP External Lubrication System Fittings

ILLUSTRATION NUMBER	QUANTITY REQUIRED	PART DESCRIPTION	PART NUMBER
1	1	Lubrication Gun Fitting, Alemite #1650	006-24-145-00
2	1	1/8" NPT Valve	950752
3	1	1/8" x 3-3/4" lg. Pipe Nipple (275# Only)	950763
4	1	1/8" x 5" lg. Pipe Nipple (1440# Only)	950764

3" T-10 HP External Lubrication System Fittings

1	1	Lubrication Gun Fitting	006-24-145-00
2	1	1/8" NPT Valve	950752
3	1	1/8" x 3-3/4" lg. Pipe Nipple (1440#)	950763

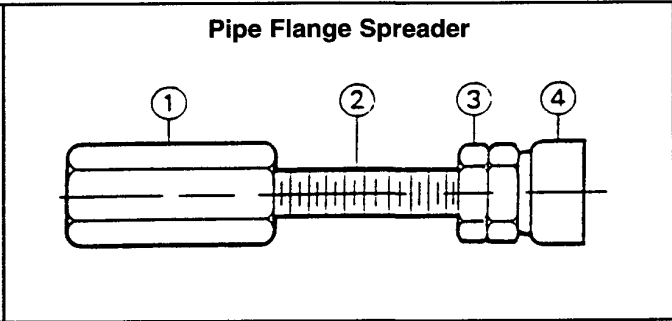
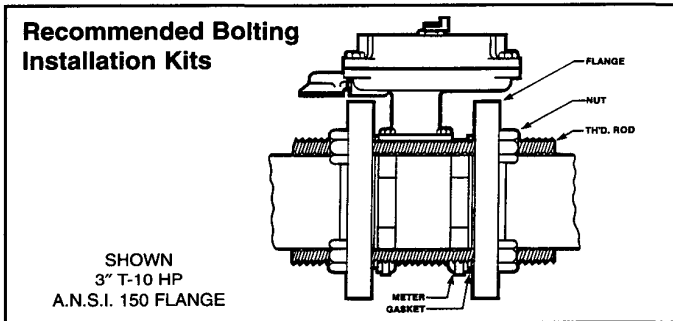

METER MODEL	FLANGE RATING	GASKET NUMBER	THREADED ROD SIZE	RODS REQ'D	NUT SIZE	NUTS REQ'D	INSTALLATION KIT NUMBER
2" T-10 HP	ANSI 150	950790	5/8"-11 x 12" Long, 950534	4	5/8"-11, 920557	8	00615-373-00000
2" T-10 HP	ANSI 300 ANSI 600	950791	5/8"-11 x 12" Long, 950534	8	5/8"-11, 920557	16	00615-373-80000
3" T-10 HP	ANSI 150	950792	5/8"-11 x 9-1/2" Long, 950533	4	5/8"-11, 920557	8	00619-373-00000
3" T-10 HP	ANSI 300 ANSI 600	950793	3/4"-10 x 11" Long, 950536	8	3/4"-10, 920558	16	00619-373-80000

NOTE: Recommended threaded rod material is A.S.T.M. A-320 GR L7M.

Pipe Flange Spreader

COMPONENTS ITEM	DESCRIPTION
1	Coupling Nut, 1/2"-13 x 1-1/2" long
2	Stud Bolt, 1/2"-13 x 6" long, for 2" T-10 HP
3	Stud Bolt, 1/2"-13 x 3" long, for 3" T-10 HP
4	Jam Nut, 1/2"-13
5	Swivel Pad, 1/2"-13
ASSEMBLIES	
For 2" T-10 HP, Assembly Number	00615-374-80000
For 3" T-10 HP, Assembly Number	00619-374-80000

NOTE: Flange spreaders are recommended for use in pairs.



Equimeter Incorporated
805 Liberty Boulevard
P.O. Box 528
DuBois, PA 15801



LIMITED WARRANTY Seller warrants the Goods to be free from defects in materials manufactured by Seller and in Seller's workmanship for a period of [one (1) year] after tender of delivery (the "Warranty Period"). **THIS LIMITED WARRANTY (a) IS IN LIEU OF, AND SELLER DISCLAIMS AND EXCLUDES, ALL OTHER WARRANTIES, STATUTORY, EXPRESS OR IMPLIED, INCLUDING, WITHOUT LIMITATION, ANY WARRANTY OF MERCHANTABILITY OR FITNESS FOR A PARTICULAR PURPOSE, OR OF CONFORMITY TO MODELS OR SAMPLES;** (b) does not apply to any Goods which have been (i) repaired, altered or improperly installed; (ii) subjected to improper use or storage; (iii) used or incorporated with other materials or equipment, after Buyer or anyone using the Goods has, or reasonably should have, knowledge of any defect or nonconformance of the Goods; or (iv) manufactured, fabricated or assembled by anyone other than Seller; (c) shall not be effective unless Buyer notifies Seller in writing of any purported defect or nonconformance within [thirty (30) days] after Buyer discovers or should have reasonably discovered such purported defect or nonconformance; and (d) shall only extend to Buyer and not to any subsequent buyers or users of the Goods. Buyer shall provide Seller access to the Goods as to which Buyer claims a purported defect or nonconformance; upon request by Seller, Buyer shall, at its own risk and expense, promptly return the Goods in question to Seller's Plant.